

## ORDERING CODE - S6E SERIES

**S6E \* - 052 - 1 R 00 - S 1**

**Series** \_\_\_\_\_

**Y** - Metric port connection, Omit for UNC \_\_\_\_\_

**Cam ring** \_\_\_\_\_

Volumetric displacement cm<sup>3</sup>/rev (in<sup>3</sup>/rev)

042 = 132.3 (8.07)  
 045 = 142.4 (8.69)  
 050 = 158.5 (9.67)  
 052 = 164.8 (10.06)  
 057 = 180.7 (11.02)  
 062 = 196.7 (12.00)  
 066 = 213.3 (13.02)  
 072 = 227.1 (13.86)  
 085 = 269.8 (16.46)

**Type of shaft** \_\_\_\_\_

1 - keyed (SAE CC)  
 2 - keyed (no SAE)  
 3 - splined (SAE C)  
 4 - splined (SAE CC)

**Seal class**

1 - S1 (for mineral oil)  
 4 - S4 (for fire resistant fluids)  
 5 - S5 (for mineral oil and fire resistant fluids)

**Design letter**

**Porting combination**

00 - standard

**00** **01** **02** **03**

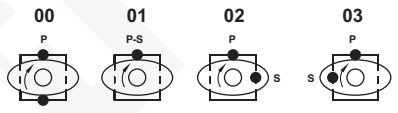

**S** Suction port **P** - Pressure port

**Direction of rotation (view on shaft end)**

R - clockwise  
 L - counter-clockwise

### OPERATING CHARACTERISTICS - TYPICAL (24 cST)

Pressure port	Series	Volumetric Displacement V <sub>p</sub>		Flow q & n = 1500 rpm						Input power r p & n = 1500 rpm					
				p = 0 bar (0 psi)		p = 140 bar (2000 psi)		p = 240 bar (3500 psi)		p = 7 bar (100 psi)		p = 140 bar (2000 psi)		p = 240 bar (3500 psi)	
				in <sup>3</sup> /rev	cm <sup>3</sup> /rev	gpm	lpm	gpm	lpm	gpm	lpm	hp	kw	hp	kw
<b>VT6E</b>	042	8.07	132.3	52.50	198.5	49.87	188.5	47.96	181.3	6.97	5.2	66.25	49.4	110.77	82.6
	045	8.70	142.4	56.51	213.6	53.86	203.6	51.98	196.5	7.24	5.4	70.94	52.9	118.95	88.7
	050	9.67	158.5	62.88	237.7	60.24	227.7	58.36	220.6	7.64	5.7	78.45	58.5	131.82	98.3
	052	10.00	164.8	65.40	247.2	62.75	237.2	60.87	230.1	7.78	5.8	81.53	60.8	136.92	102.1
	057	11.02	180.7	71.71	271.1	69.07	261.1	67.19	254.0	8.18	6.1	89.04	66.4	143.35	106.9
	062	12.00	196.7	78.04	295.0	75.40	285.0	73.52	277.9	8.58	6.4	96.42	71.9	162.67	121.3
	066	13.00	213.3	84.63	319.9	81.98	309.9	80.11	302.8	8.98	6.7	104.20	77.7	175.94	131.2
	072	13.86	227.1	90.11	340.6	87.46	330.6	85.58	323.5	9.25	6.9	110.77	82.6	187.07	139.5
	085 <sup>1)</sup>	16.40	269.8	107.00	404.7	105.21 <sup>2)</sup>	397.7 <sup>2)</sup>	--	--	9.78	7.3	87.56 <sup>2)</sup>	65.3 <sup>2)</sup>	--	--

1) 085 = 2000 RPM max.

2) 085 = 75 bar (1100 psi) cont.

085 = 90 bar (1300 psi) max. int.

# DIMENSIONS - S6E SERIES

**WEIGHT : 43.4 Kg.**

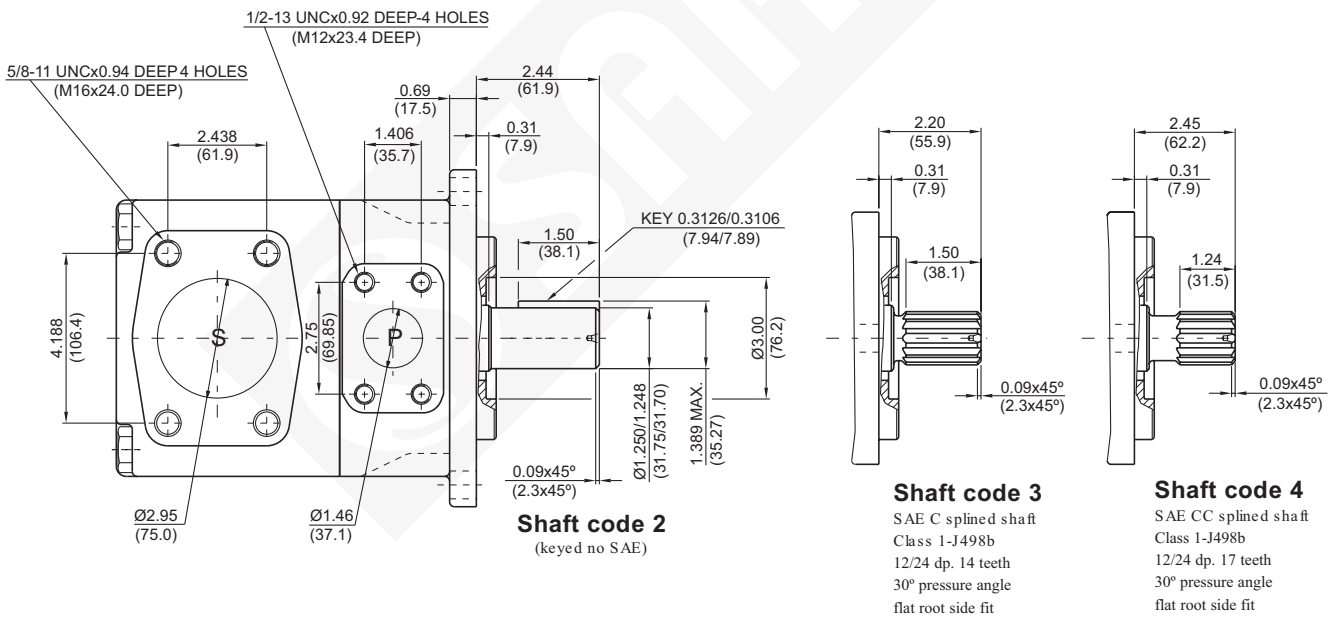
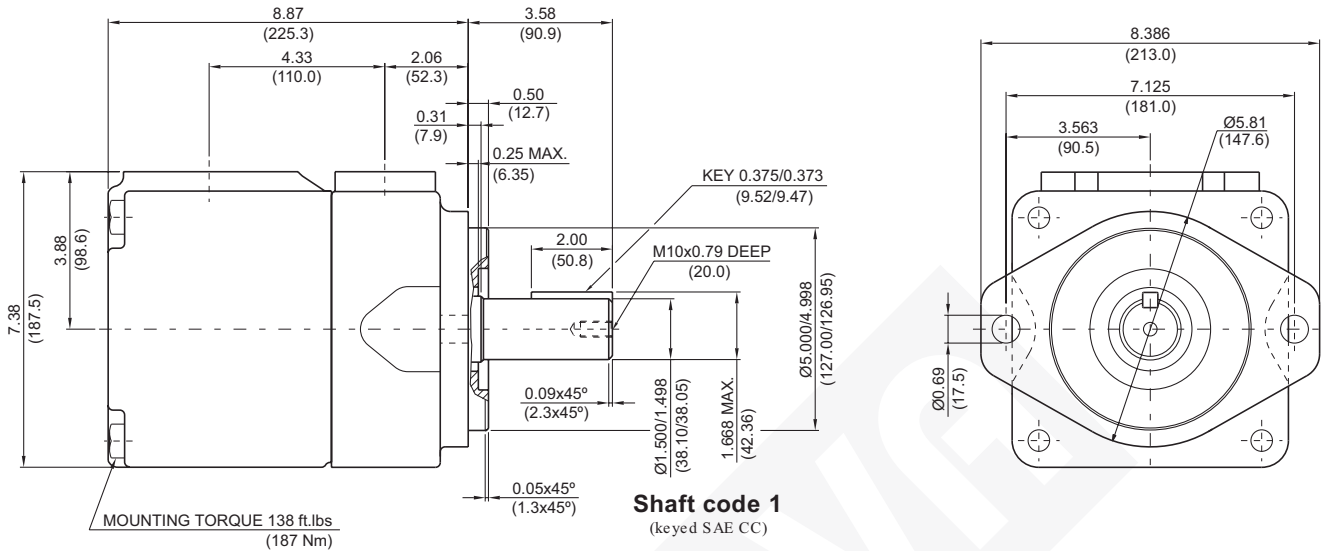

**Shaft torque limits in<sup>3</sup>/rev x psi (ml/rev x bar)**

Shaft	Vp x p max.
1	48273 (54555)
2	30638 (34590)
3	54207 (61200)
4	54207 (61200)