

ORDERING CODE - S6EC SERIES

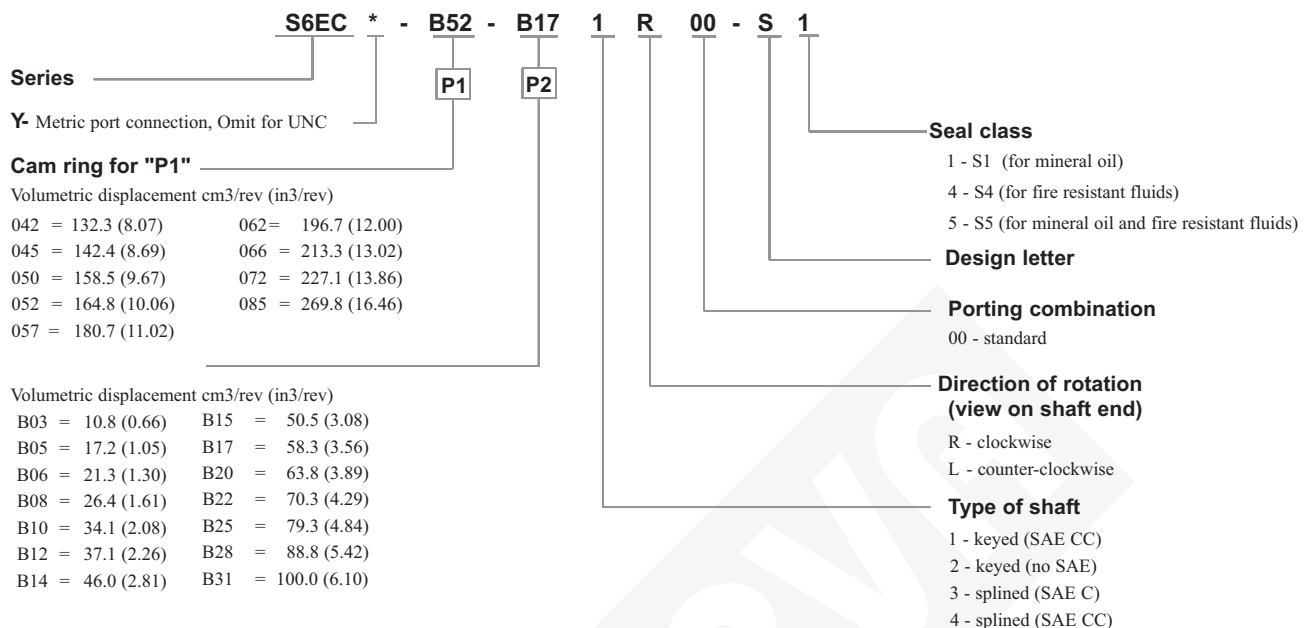

OPERATING CHARACTERISTICS - TYPICAL (24 cST) (Input power p (KW) for one cartridge only)

Pressure port	Series	Volumetric Displacement V _p		Flow q & n = 1500 rpm						Input power p & n = 1500 rpm					
		in ³ /rev	cm ³ /rev	p = 0 bar (0 psi)		p = 140 bar (2000 psi)		p = 240 bar (3500 psi)		p = 7 bar (100 psi)		p = 140 bar (2000 psi)		p = 240 bar (3500 psi)	
				gpm	lpm	gpm	lpm	gpm	lpm	hp	kw	hp	kw	hp	kw
P1	042	8.07	132.3	52.50	198.5	49.87	188.5	47.96	181.3	6.97	5.2	66.25	49.4	110.77	82.6
	045	8.70	142.4	56.51	213.6	53.86	203.6	51.98	196.5	7.24	5.4	70.94	52.9	118.95	88.7
	050	9.67	158.5	62.88	237.7	60.24	227.7	58.36	220.6	7.64	5.7	78.45	58.5	131.82	98.3
	052	10.00	164.8	65.40	247.2	62.75	237.2	60.87	230.1	7.78	5.8	81.53	60.8	136.92	102.1
	057	11.02	180.7	71.71	271.1	69.07	261.1	67.19	254.0	8.18	6.1	89.04	66.4	143.35	106.9
	062	12.00	196.7	78.04	295.0	75.40	285.0	73.52	277.9	8.58	6.4	96.42	71.9	162.67	121.3
	066	13.00	213.3	84.63	319.9	81.98	309.9	80.11	302.8	8.98	6.7	104.20	77.7	175.94	131.2
	072	13.86	227.1	90.11	340.6	87.46	330.6	85.58	323.5	9.25	6.9	110.77	82.6	187.07	139.5
	085 ⁽¹⁾	16.40	269.8	107.00	404.7	105.21 ⁽²⁾	397.7 ⁽²⁾	--	--	9.78	7.3	87.56 ⁽²⁾	65.3 ⁽²⁾	--	--
P2	B03	0.66	10.8	4.29	16.2	2.96	11.2	2.04	7.7	1.74	1.3	7.11	5.3	11.22	8.4
	B05	1.05	17.2	6.83	25.8	5.50	20.8	4.57	17.3	1.88	1.4	10.06	7.5	16.36	12.2
	B06	1.30	21.3	8.44	31.9	7.11	26.9	6.19	23.4	2.01	1.5	11.94	8.9	19.71	14.7
	B08	1.61	26.4	10.48	39.6	9.15	34.6	8.22	31.1	2.15	1.6	14.35	10.7	22.93	17.7
	B10	2.08	34.1	13.52	51.1	12.19	46.1	11.26	42.6	2.28	1.7	18.64	13.4	29.90	22.3
	B12	2.26	37.1	14.71	55.6	13.36	50.6	12.46	47.1	2.28	1.7	19.31	14.4	32.32	24.1
	B14	2.81	46.0	18.25	69.0	16.93	64.0	16.00	60.5	2.55	1.9	23.60	17.6	39.56	29.5
	B15	3.08	50.5	20.00	75.6	18.73	73.2	19.02	67.5	2.68	2.0	25.61	19.1	42.91	32.0
	B17	3.56	58.3	23.12	87.4	21.79	82.4	20.87	78.9	2.82	2.1	29.37	21.9	49.48	36.9
	B20	3.89	63.8	25.32	95.7	23.99	90.7	23.07	87.2	2.95	2.2	31.92	23.8	53.91	40.2
	B22	4.29	70.3	27.88	105.4	26.56	100.4	25.63	96.9	3.08	2.3	35.00	26.1	59.14	44.1
	B25	4.84	79.3	31.46	118.9	30.13	113.9	29.21	110.4	3.35	2.5	39.16	29.2	66.38	49.5
	B28	5.42	88.8	35.24	133.2	33.92	128.2	33.28 ⁽³⁾	125.8 ⁽³⁾	3.75	2.8	43.85	32.7	65.04 ⁽³⁾	48.5 ⁽³⁾
B31	6.10	100.0	39.68	150.0	38.35	145.0	37.72 ⁽³⁾	142.6 ⁽³⁾	3.75	2.8	48.95	36.5	72.95 ⁽³⁾	54.4 ⁽³⁾	

(1) 085 = 2000 RPM max. (2) 085 = 75 bar (1100 psi) cont. 085 = 90 bar (1300 psi) max. int. (3) B28-B31 = 210 bar (3000 psi) max. (4) B03-B22 = 300 bar (4350 psi) max.

DIMENSIONS - S6EC SERIES

WEIGHT : 55.2 Kg.

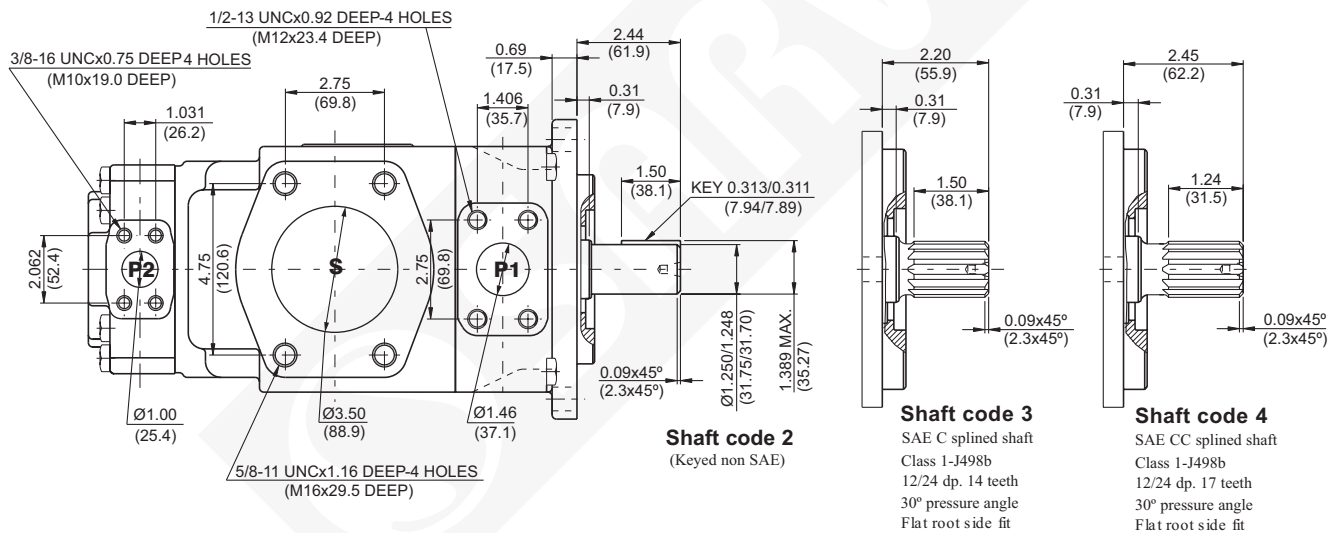
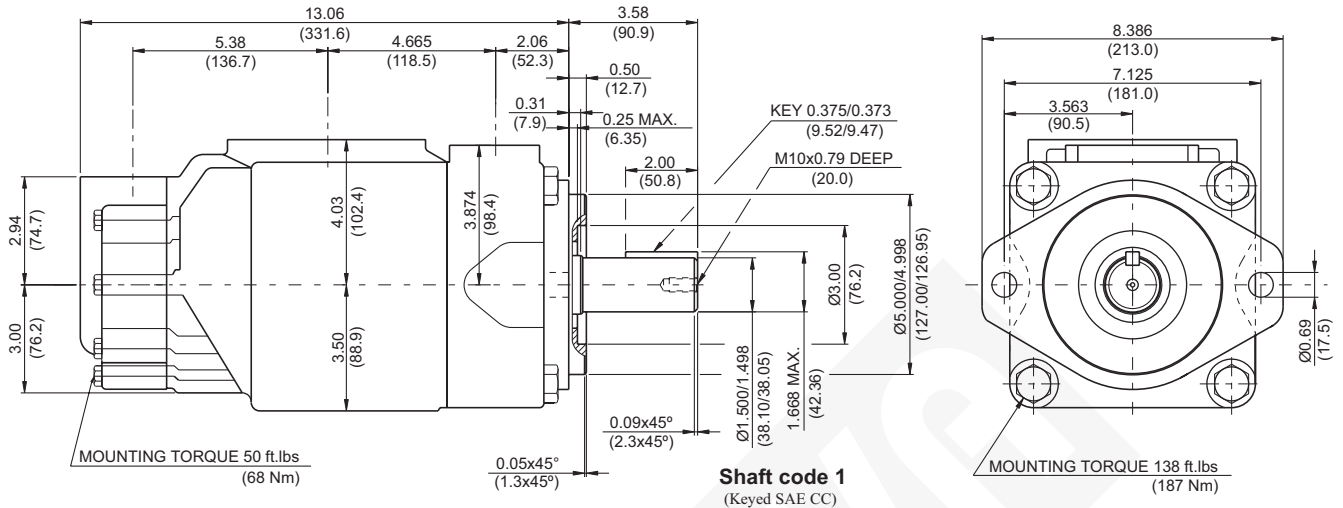

Shaft torque limits in ³ /rev x psi (ml/rev x bar)	
Shaft	V _p x p max. (P1+P2)
1	64044 (72306)
2	30638 (34590)
3	54207 (61200)
4	67582 (76376)

Porting Diagrams

